

GIE Inc.

Global Industrial Equipment, Inc.

THE ANSWER TO CORROSION

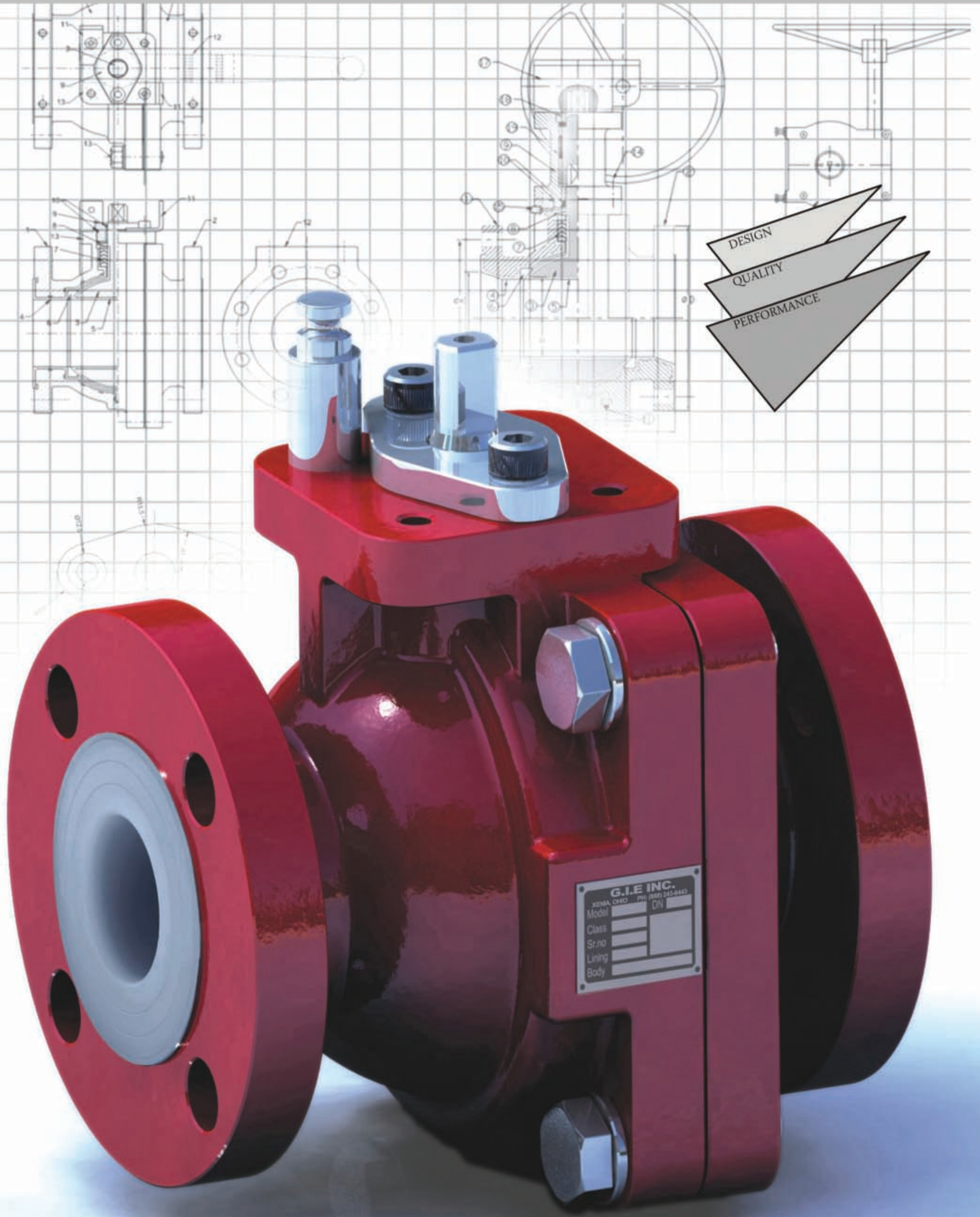

PLASTIC LINED FULL PORT

BALL VALVE

LININGS : PFA FEP PVDF ETFE PP

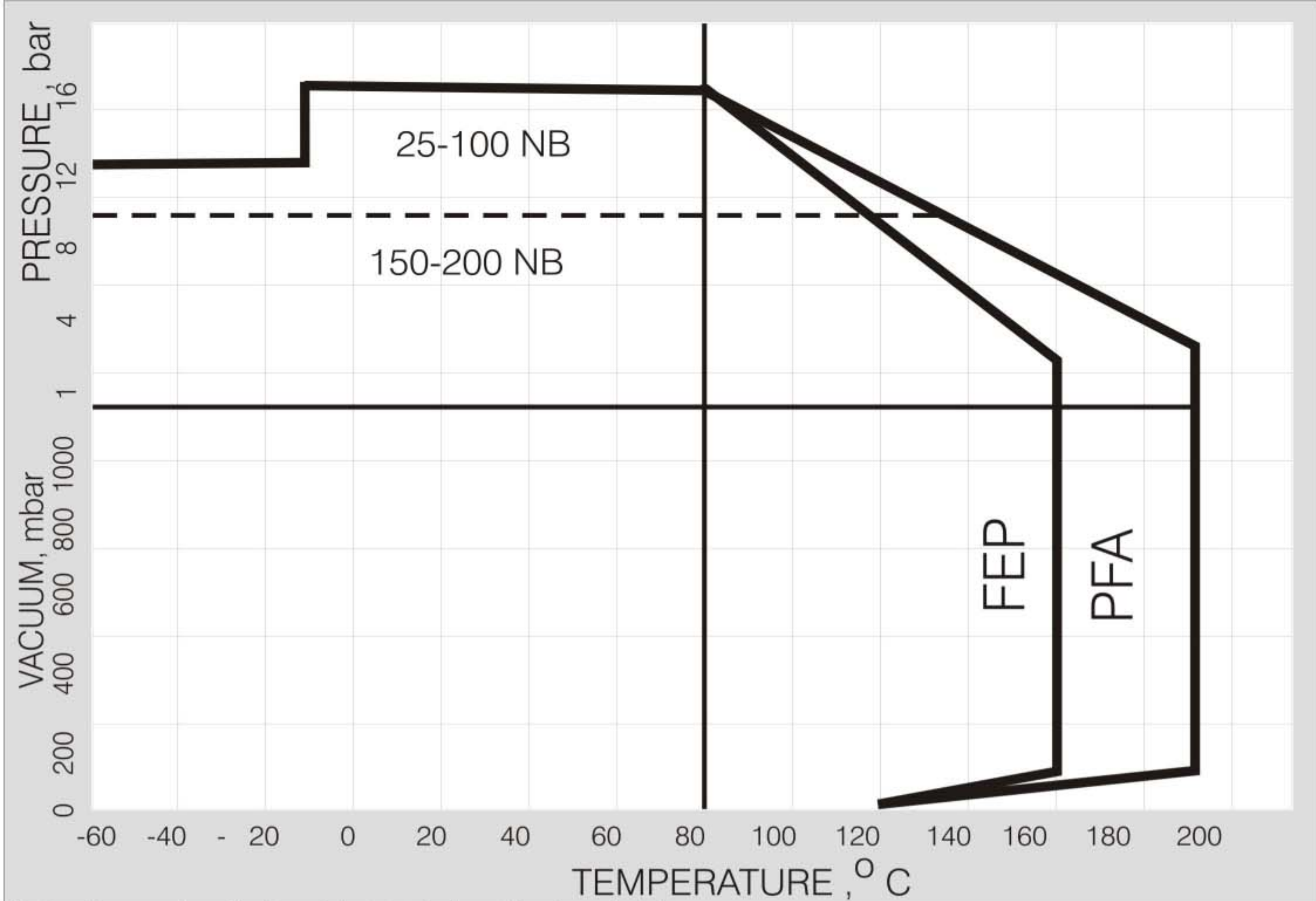

Note : Temperature limits subject to choice of body material

SIZE		APPROX. WEIGHT		TORQUE , Kgm		FLOW RATE	
				@ ΔP=10 bar / 150psi		Kvs	Cv
inch	NB	lb.	Kg.	Oper.	Max. permitted	m3/h	US gpm
1/2"	15NB	6.2	2.8	0.5	1	17.4	20.5
3/4"	20	12.1	5.5	1	1.8	61	70.5
1"	25NB	12.1	5.5	1	1.8	61	70.5
1 1/2"	40NB	26.4	12	2	5	188	219
2"	50NB	33	15	3.2	8	276	321
3"	80NB	63.8	29	7.5	16	591	692
4"	100NB	101.2	46	19.5	32	1247	1451
6"	150NB	168.3	76.5	28	50	2755	3215

GIE Inc. Global Industrial Equipment, Inc.

Distributed Locally By:

479 BELLBROOK AVENUE
 XENIA, OHIO 45385
 Toll Free: 888-243-8443
 Fax: 937-374-1361
 Email: info@gieinc.com
 Website: www.gieinc.com

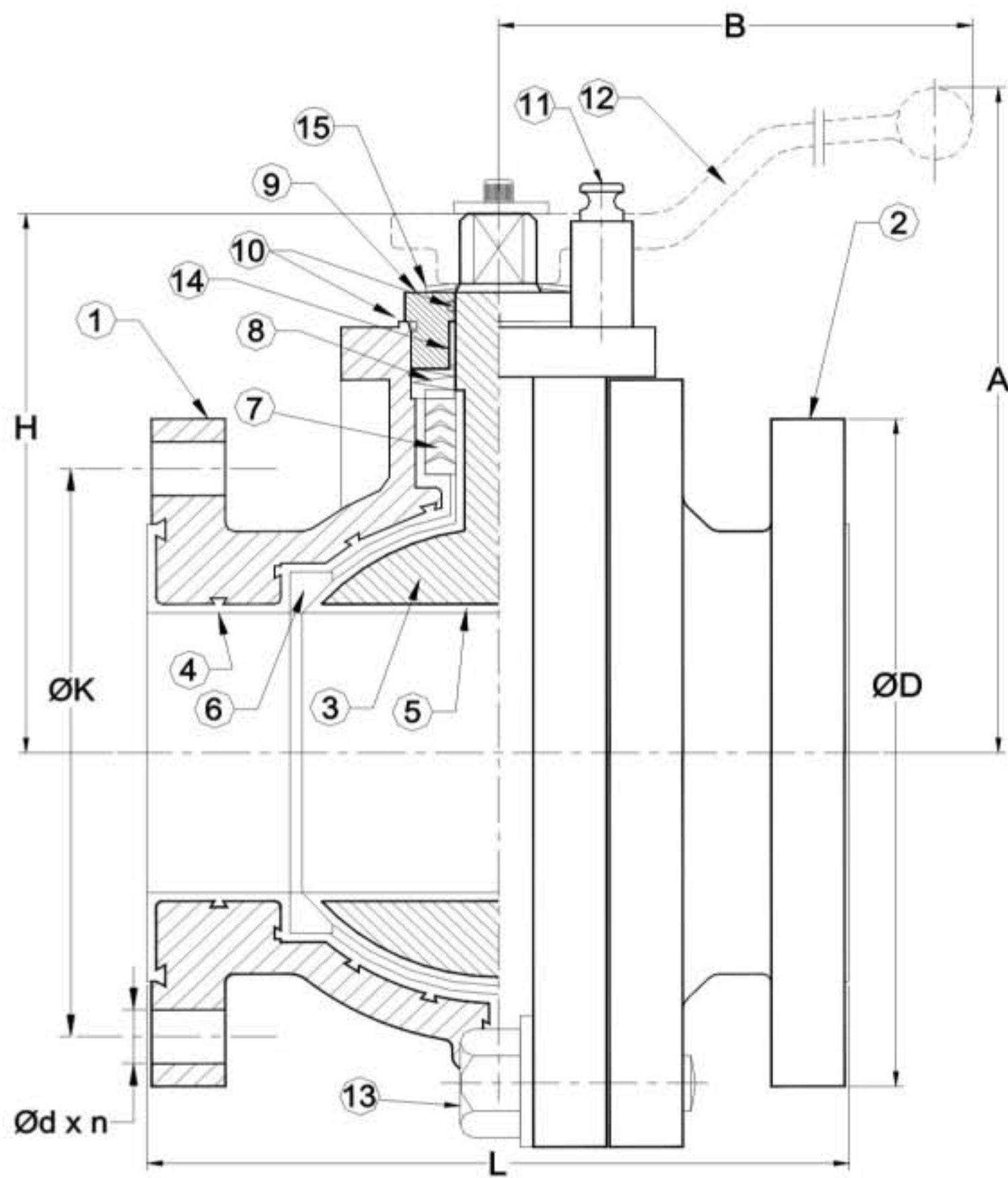

SIZE NB	.5" (15)	.75" (20)	1" (25)	1.5" (40)	2" (50)	3" (80)	4" (100)	6" (150)
T	.39" (10)	.43" (11)	.43" (11)	.59" (15)	.59" (15)	.71" (18)	.71" (18)	.79" (20)
G	.16" (4)	.27" (5.5)	.27" (5.5)	.31" (8)	.31" (8)	.39" (10)	.39" (10)	.39" (10)
S	.31" (8)	.47" (8)	.47" (8)	.55" (14)	.71" (18)	.87" (22)	.98" (25)	1.10" (28)
N	.39" (10)	.51" (13)	.51" (13)	.63" (16)	.79" (20)	.94" (24)	1.10" (28)	1.18" (30)
F	.24" (6)	.35" (9)	.35" (9)	.43" (11)	.55" (14)	.67" (17)	.75" (19)	.87" (22)
J	1.42" (36)	1.97" (50)	1.97" (50)	2.76" (70)	2.76" (70)	3.15" (80)	4.02" (102)	4.02" (102)
W	1.57" (40)	2.36" (60)	2.36" (60)	2.99" (76)	3.07" (78)	3.74" (95)	4.04" (102.5)	4.33" (110)
X	.10" (7)	.47" (12)	.47" (12)	.79" (20)	.79" (20)	.94" (24)	.94" (24)	.94" (24)
Y	.04" (1)	.08" (2)	.08" (2)	.12" (3)	.12" (3)	.12" (3)	.12" (3)	.12" (3)
M	M5	M6	M6	M8	M8	M10	M10	M10
P	1.10" (28)	1.25" (3.18)	1.25" (3.18)	1.65" (41.9)	1.74" (44.3)	2.24" (56.8)	2.56" (64.9)	2.98" (75.8)
Q	.24" (6)	.24" (6)	.24" (6)	.31" (8)	.31" (8)	.31" (8)	.39" (10)	.39" (10)
R	56°	72°	72°	69°	68°	66°	62°	59°

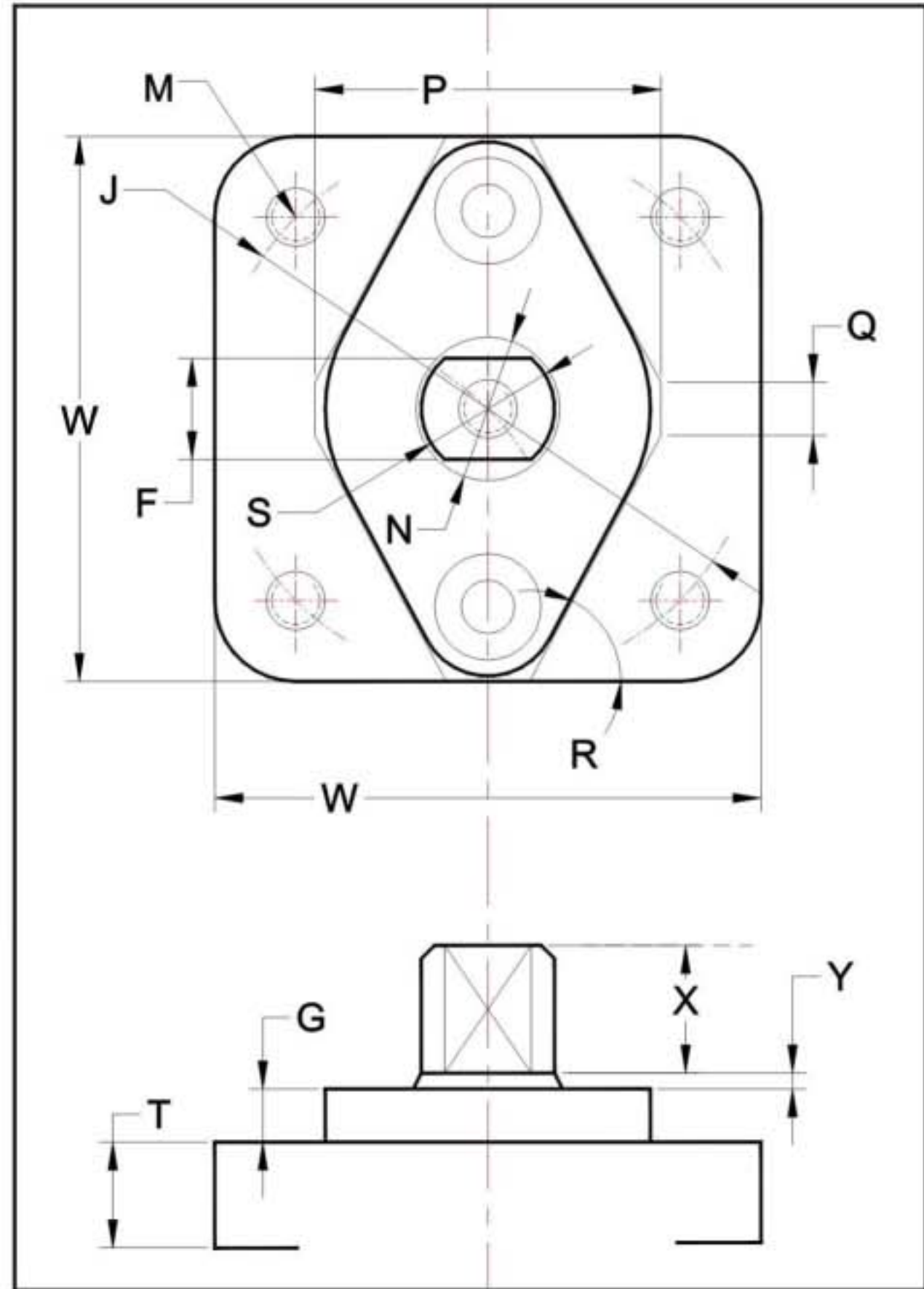

SIZE NB	.5" (15)	.75" (20)	1" (25)	1.5" (40)	2" (50)	3" (80)	4" (100)	6" (150)
L	4.37" (111)	4.61" (117)	5" (127)	6.5" (165)	7" (178)	8" (203)	9" (229)	10.5" (267)
B	3.94" (100)	6.89" (175)	6.89" (175)	8.86" (225)	9.84" (250)	11.81" (300)	13.78" (350)	23.62" (600)
ØD	3.50" (89)	3.87" (98.4)	4.25" (108)	5" (127)	6" (152.4)	7.5" (190.5)	9.02" (229)	10.98" (279)
Ød x n	.63" X 4 (16) X 4	.63" X 4 (16) X 4	.63" X 4 (16) X 4	.63" X 4 (16) X 4	.75" X 4 (19) X 4	.75" X 4 (19) X 4	.75" X 8 (19) X 8	.91" X 8 (23) X 8
ØK	2.37" (60.3)	2.75" (69.8)	3.13" (79.5)	3.87" (98.4)	4.75" (120.7)	6" (152.4)	7.5" (190.5)	9.5" (241.3)
H	2.32" (59)	2.32" (59)	3.39" (86)	4.57" (116)	4.88" (124)	6.14" (156)	7.28" (185)	8.94" (227)
A	3.35" (85)	3.35" (85)	4.92" (125)	6.30" (160)	7.09" (180)	8.66" (220)	9.84" (250)	10.63" (270)

Other standards or ratings can be provided on request
 All Diminsions are in Inches and Millimeters
 Face to Face dimensions as per ANSI B16.10
 Flange dimensions as per ASTM B16.42 150#
 Tolerances as per applicable standards.
 8" / 200NB Size available with standard port

MATERIAL SPECIFICATION

No.	Description	Standard Material	Optional Material	Qty.
1	Body A	ASTM A395 / EN-GJS-400-18-RT	ASTM A216 Gr. WCB / A351 Gr. CF8	1
2	Body B	ASTM A395 / EN-GJS-400-18-RT	ASTM A216 Gr. WCB / A351 Gr. CF8	1
3	Ball-Stem	ASTM A351 Gr. CF8	ASTM A351 Gr. CF8M	1
4	Body Lining	PFA / FEP	ETFE / PVDF / PP	1
5	Ball lining	PFA / FEP	ETFE / PVDF / PP	1
6	Seat rings	PTFE	Modified PTFE (TFM)	2
7	Packing ring set	PTFE	Modified PTFE (TFM)	1
8	Disc spring set	AISI 304		1
9	Packing Gland	ASTM A351 Gr. CF8	ASTM A351 Gr. CF8M	1
10	O-ring seal set	Viton		1
11	Lever stopper (Lockable)	AISI 304	AISI 316 / AISI 316L	2
12	Lever	ASTM A216 Gr. WCB	ASTM A351 Gr. CF8 / CF8M	1
13	Fasteners	AISI 304	AISI 316 / AISI 316L	1
14	Bearing bush	Carbon filled PTFE	Graphite filled PTFE	1
15	Anti-Static device	AISI 304		1

PRODUCT CONFIGURATIONS

SPECIAL "V" PORT BALL FOR
IMPROVED FLOW CONTROL

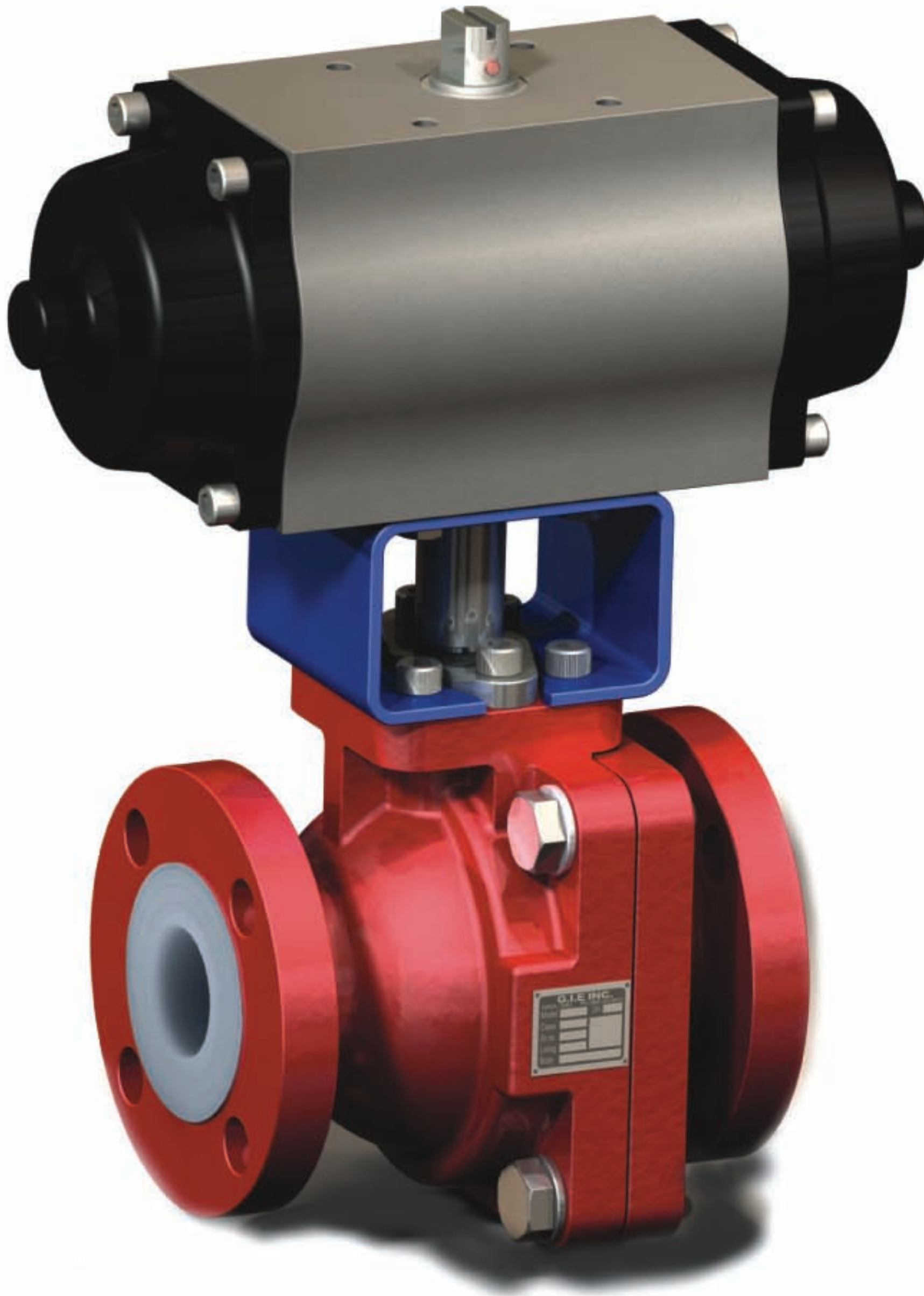

BALL VALVE WITH ACTUATOR MOUNTED
USING A BRACKET AND ADAPTER



BALL VALVE WITH EXTENDED
STEM AND ISO 5211
ACTUATOR MOUNTING FLANGE

MANUALLY OPERATED BALL VALVE
WITH LOCKABLE LEVER

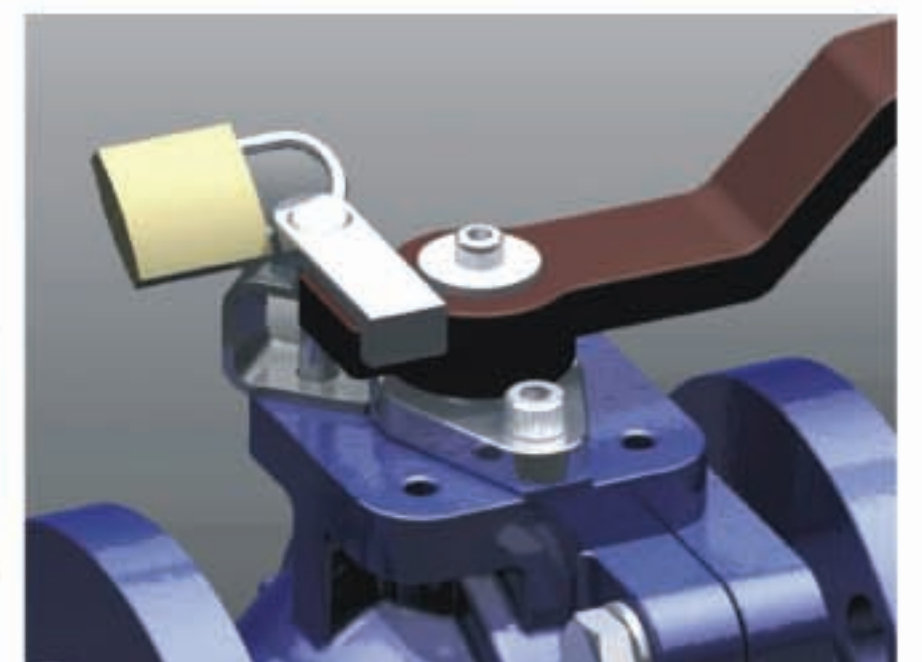

Design features and quality assurance.

- Cast ductile iron shell conforming to ASTM A395 ensures quality and toughness.
- One piece ball/stem design prevents any ball-stem hysteresis and guarantees accurate positioning of ball in open/close condition.
- Ball-Stem, gland cover and Levers are made in investment casting.
- Choice of four different fluoroplastic lining materials to provide corrosion and temperature resistance for almost all applications
- Extra thick locked-in-lining for high vacuum rating (minimum 3mm).
- Blow-out proof stem.
- Unique packing system. Self adjusting with permanent loading (Stainless steel Belleville springs). PTFE CHEVRON packing provides stem seal integrity while maintaining low turning torque.
- Minimum valve body cavity space reduces potential product accumulation and contamination problems
- A full bore design ensures minimum pressure-drop.
- Metal to metal body joints fully control lining compression.
- External protection against corrosion with epoxy coating, stainless steel fasteners and gland cover.
- Plastic end protectors on each flange to protect the liner faces.

The exceptional design features are complemented by a total quality program, where all lined valve components are fully checked, visually inspected and spark tested before assembly. Assembled valves are tested as per API 598 specifications to assure absolute bubble tight shut-off and zero stem leakage.

All GLOBAL INDUSTRIAL EQUIPMENT, INC. ball valves are manufactured to rigid quality control standards, meeting or exceeding industry specifications.

TECHNICAL DATA

Pressure range :
0-16 bar (see diagram)

Temperature range
(-) 60 -200 °C (see diagram)

Vacuum resistance
Full vacuum (see diagram)

Face to face
ANSI 816.10 short pattern
options-
ANSI 816.10 Long pattern
DIN 3202/F1

Flange drilling :
ANSI 816.42/816.5-150#,
options-
ANSI 816.42/816.5-300#,
DIN PN 10/16

OPTIONAL FEATURES

Lockable handles: For applications which require protection against inadvertent opening or closing of the valve. with levers which can be locked using padlocks can be provided

Actuator mounting: For applications requiring automatic actuation and for manual actuation of large size Valves can be supplied with actuator mounting bracket and adapter for mounting of ISO 5211 compliant quarter turn actuator. Manual geared, Pneumatic or motorised actuators of international brands can also be provided.

V-Port Ball: For applications requiring improved flow control, a V-Port Ball can be optionally supplied instead of a full port ball.

Extended Stem: For applications requiring insulation of the pipe line, the valves can be supplied with an extended stem, along with an ISO 5211 actuator mounting flange.

Secondary seals: For critical applications requiring additional leakage protection, the valves can be supplied with secondary seals for stem and body flange joint.

GLOBAL INDUSTRIAL EQUIPMENT, INC.'S New 2-pc short pattern full-port, fluoroplastic lined Ball valve with an innovative design.

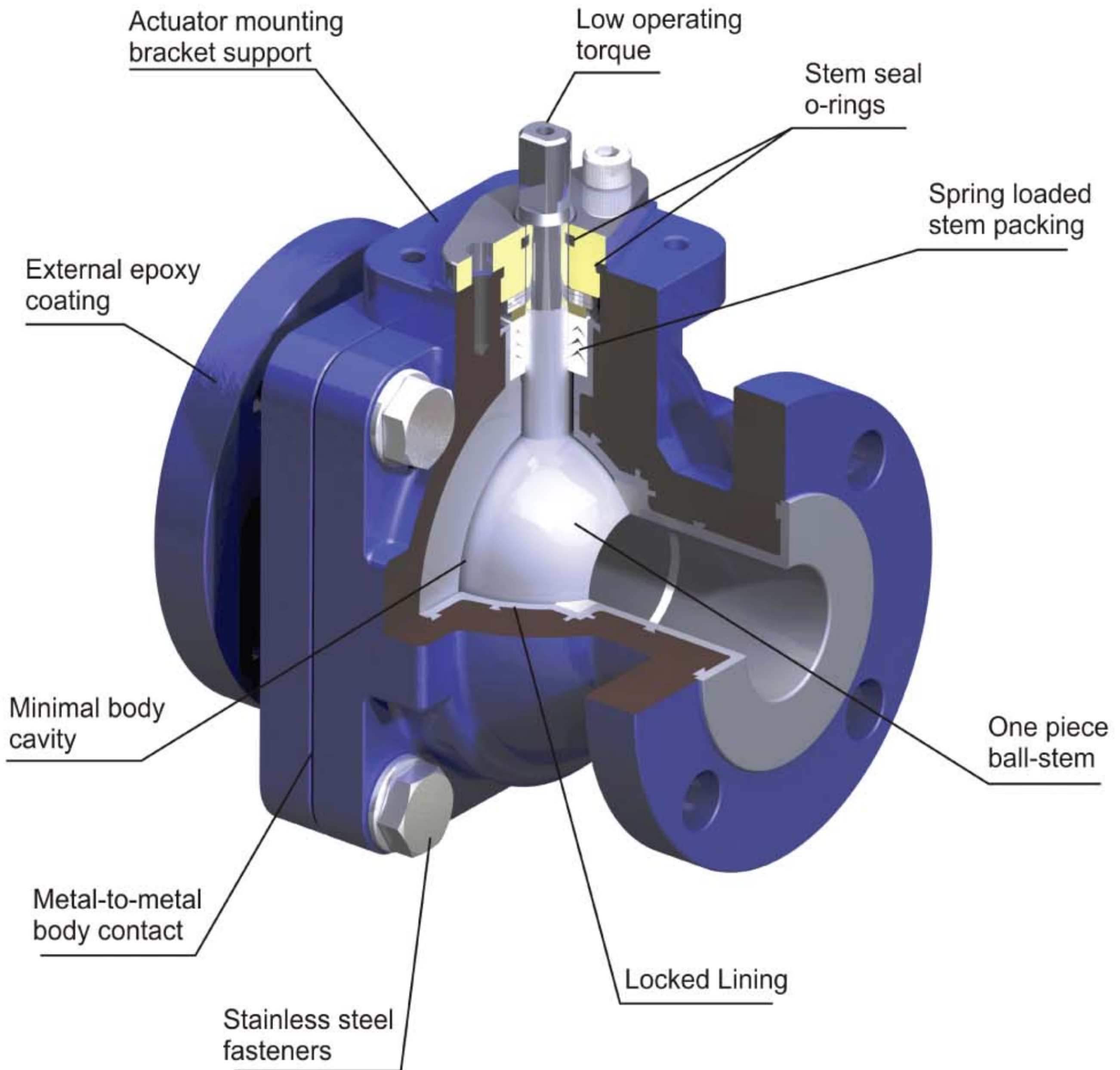

HIGHLIGHTS

- The heavy duty construction of GLOBAL INDUSTRIAL EQUIPMENT, INC. ball valves meets the stringent requirements of chemical process industry.
- GLOBAL INDUSTRIAL EQUIPMENT, INC. ball valves are specially designed for low torque, bubble tight shut-off and minimal pressure drop.
- The Fluoroplastic linings offer outstanding corrosion resistance and high degree of safety in various applications.
- GLOBAL INDUSTRIAL EQUIPMENT, INC. ball valves are virtually maintenance free and give long time service due to their quality and simplicity of design.